

## STRENGTHENING OF IMPACT-DAMAGED BRIDGE GIRDER USING FRP LAMINATES

**A. Nanni, P. C. Huang, and J. G. Tumialan**  
Center for Infrastructure Engineering Studies  
University of Missouri – Rolla  
Rolla, MO 65409, USA

**KEYWORDS:** bridge girder, bridge repair, carbon fiber, FRP, prestressed concrete, vehicular impact.

### ABSTRACT

The exterior prestressed concrete (PC) girder of Bridge A10062, located at the interchange of Interstates 44 and 270 in St. Louis County, Missouri, USA, was impact-damaged by an overheight truck. Removal of the loose concrete showed that two prestressing tendons were fractured due to the impact. This resulted in approximately 10% reduction in flexural moment capacity. There has been limited research on the repair of PC bridge girders damaged by vehicular impact. Due to the repetitive nature of highway loading, repair methods such as internal strand splices and external post-tensioning were found to be questionable because they could not restore the ultimate strength to the damaged member. In this case study, it was decided to use carbon FRP (CFRP) laminates to restore the original structural capacity of the girder. It was demonstrated CFRP bonded reinforcement could be an effective repair technique in terms of installation as well as design. If the present trend in growing availability of FRP materials and design information were to continue, a sharp increase in FRP application could be forecast.

### INTRODUCTION

Bridge A10062 is located at the interchange of the Interstates 44 and 270 in St. Louis County, Missouri, USA. With a relatively low roadway clearance of 4.47 m, it was impact-damaged by an overheight truck in one of its exterior prestressed concrete (PC) girders. Removal of the loose concrete showed that two prestressing tendons were fractured due to the impact (see Figure 1).



**Figure 1. Fractured Tendons after the Removal of the Damaged Concrete**

There has been relatively limited research on the damage assessment and repair of PC bridge girders subjected to vehicular impact. From a National Cooperative Highway Research Program (NCHRP) perspective, two publications (Shanafelt and Horn 1980 and 1985) address this topic. Researchers at Iowa State University have recently published a comprehensive report (Klaiber et al. 1999). This

Nanni, A., P.C. Huang and G. Tumialan, "Strengthening of Impact-Damaged Bridge Girder Using FRP Laminates," 9<sup>th</sup> Int. Conf., Structural Faults and Repair, London, UK, July 4-6, 2001, M.C. Forde, Ed., Engineering Technics Press, CD-ROM version, 7pp.

document includes an extensive annotated bibliography as well as results from experiments conducted in the field and in the laboratory. With respect to US experience, in addition to Iowa, Departments of Transportation of other states such as Georgia (Aboutaha et al. 1997), Minnesota (Olson et al. 1992), and Texas (Zobel et al. 1997) have supported work in this area.

Under the repetitive nature of highway loading, repair methods such as internal strand splices and external post-tensioning were found to be only partially satisfactory because they could not restore the ultimate strength to the damaged member (Olson et al. 1992; Zobel and Jirsa 1998). Strengthening of reinforced concrete (RC) and PC structures using externally bonded steel plates and composite laminates has proven to be an effective method for decreasing or restoring structural capacity (Dolan et al. 1999). Fiber reinforced polymer (FRP) composites come in the form of pre-cured laminates or fiber sheets to be installed by hand lay-up. The application of the latter offers several advantages such as ease of bonding to curved or irregular surfaces, lightweight, and the fact that fibers can be oriented along any direction. Strengthening of impact-damaged girders with FRP laminates has already been explored (Nanni 1997). In this case study, it was decided to use carbon FRP (CFRP) laminates installed by manual lay-up to restore the original structural capacity of the girder.

## MATERIAL PROPERTIES

### PC girder and deck

The damaged girder was prestressed by 20 low-relaxation 7-wire steel strands with a tensile strength of 1862 MPa. The cross section of the damaged girder and prestressing details are shown in Figure 2. Material properties used in the analysis are shown in Table 1. It was assumed that a portion of the bridge deck with dimensions of 21.6 × 122 cm provided composite action with the girder as shown in Figure 2.

**Table 1. Material Properties**

Prestressing Tendons	Strand Type	Low Relaxation
	Strand Tensile Strength (MPa)	1,862
	Nominal Diameter (mm)	12.7
	Strand Area (mm <sup>2</sup> )	98.71
	Modulus of Elasticity, (GPa)	19.31
Concrete	Existing Concrete Deck, (MPa)	34.5
	PC Girder, (MPa)	56.0

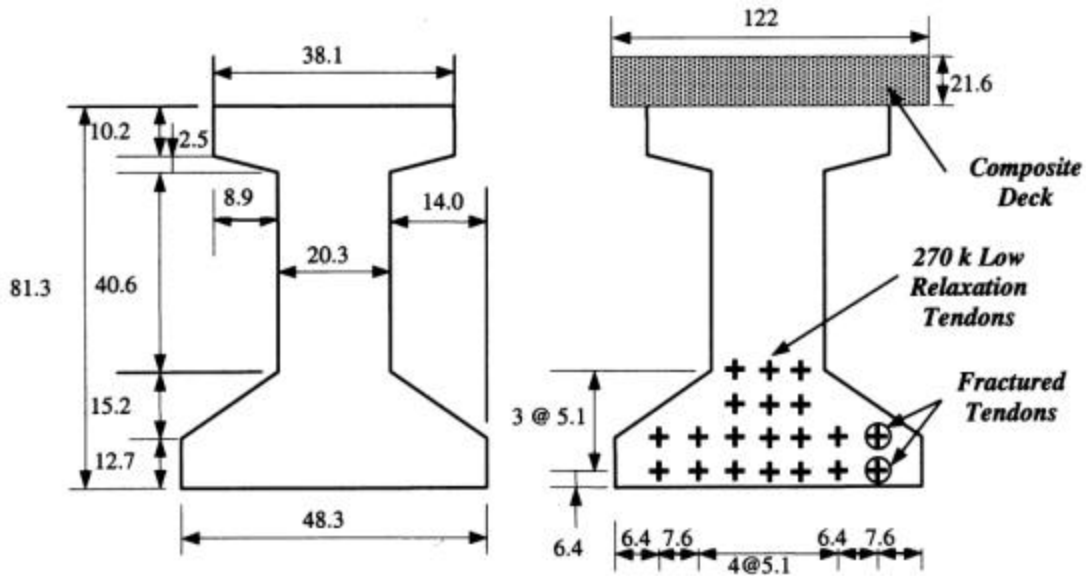

Figure 2. Girder Dimensions and Prestressing Details (dimensions in cm)

FRP laminate

Primer, putty, carbon fiber sheets, and impregnating resin (i.e., saturant) were provided by Master Builders Technologies of Cleveland, OH (MBT 1998). In this system, carbon fibers are initially dry, unidirectionally oriented, and supported by a paper backing for ease of installation by manual lay-up. According to manufacturer’s literature, the FRP tensile strength is 4,275 MPa, the modulus of elasticity is 22.8 GPa, and the design thickness is 0.165 mm. Note that, tensile strength and elastic modulus of the saturant is neglected in computing the strength of the system. Therefore, FRP laminate properties are calculated and reported (see Table 2) using the net fiber area. In tension, the CFRP laminate has a linear elastic behavior up to failure.

**Table 2. Properties of Carbon FRP (MBT 1998)**

Ultimate Strength (MPa), $f_{pu}$	4,275
Design Strength (MPa), $f_{fe}$	3,792
Tensile Modulus (GPa), $E_f$	22.8
Thickness (mm), $t_f$	0.165
Ultimate Strain (mm/mm), $\epsilon_{fu}$	0.0166

**DESIGN OF THE REPAIR**

The nominal moment capacity of the PC girder plus concrete deck was determined by the conventional rectangular stress block approach. The stress in the tendons at ultimate was determined according to standard equations (PCI 1999). The computed factored moment capacity before damage was  $fM_{n(original)} = 2,841$  kN-m. As a result of the impact-damage, the capacity of the member was reduced to  $fM_{n(damaged)} = 2,556$  kN-m. Thus, strengthening had to restore a loss of about 285 kN-m of moment capacity.

The parameters which affect the design of the strengthening of concrete flexural members have been investigated and used for many applications (Nanni et al. 1998). Included in the design protocol are the effects of initial strain, FRP/steel reinforcement ratios, material properties, steel reinforcing stress at

working loads, deflections under working loads, and failure mechanisms. Pseudo-ductility can also be addressed by considering the failure mechanism and the strain in the steel reinforcement at ultimate. The input requirements for the design of an FRP strengthened and/or stiffened concrete flexural member include existing concrete section, imposed loads (at installation and service), global geometry, and material properties. It is further assumed that the FRP laminate is externally bonded to the concrete surface when the concrete surface itself is subjected to a given level of strain and that perfect bond exists between FRP and concrete. The fundamental steps of the adopted design procedure are listed below:

- Calculate critical section moment and curvature at yield of reinforcing steel
- Calculate tensile strain in existing member at the level where FRP is to be applied
- Calculate the area of FRP required to resist ultimate projected moment
- Check stress/strain at working loads
- Determine overall length of the FRP plies and laminate
- Check ductility of the system
- Check deflection under transitory loads

The rehabilitation of this impact-damaged girder called for concrete repair and application of CFRP laminates. The flexural strengthening consisted of two 45.7cm wide plies with lengths of 285 and 325 cm, respectively, applied to the bottom of the girder with fibers aligned along its longitudinal axis. The double ply-laminate was centered over the damaged area (see Figure 3). Sixteen strips, 10.2 cm wide and spaced at 20.4 cm on centers, were then U-wrapped around the bulb of the girder over the previous installation (see Figure 4). The purpose of the U-wrap is to prevent the delamination of the FRP plies applied to the bottom surface of the girder. After repair, the factored capacity of the girder was computed to be  $fM_{n( repaired )} = 3,035$  kN-m, which is 7 % larger than the original capacity.

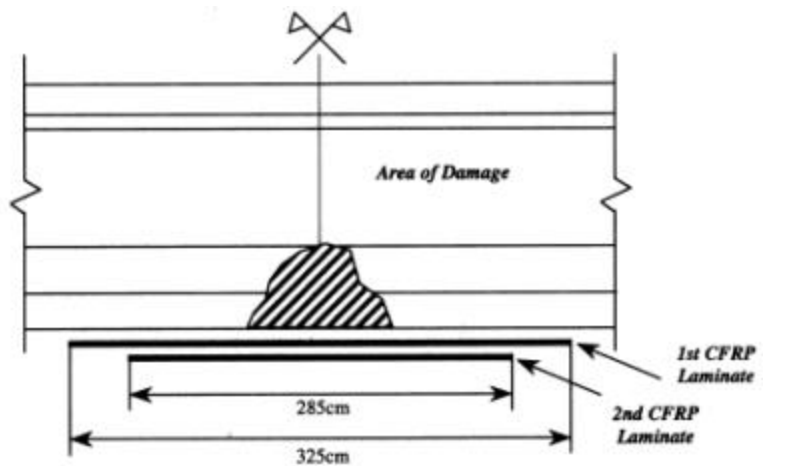

(a) Side View

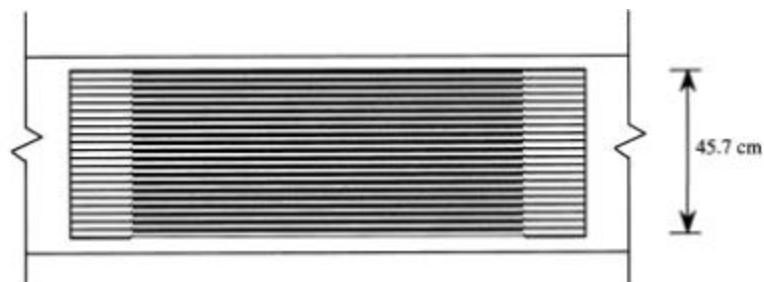

(b) Bottom View

**Figure 3. Installation of a Two-Ply CFRP Laminate (dimensions in cm)**

#### INSTALLATION

Before carrying out the CFRP laminate installation, the damaged area of the girder was restored with a rapid setting, no-shrinkage, cementitious mortar. The sequential installation procedure was as follows:

*Surface Preparation.* The bottom edges of the girder were rounded for proper wrapping.

Next, the concrete surface was sandblasted until the aggregate was exposed and the surface of the concrete was free of loose and unsound materials.

*Application of the primer.* A layer of epoxy-based primer was applied to the prepared concrete surface using a short nap roller to penetrate the concrete pores and to provide an improved substrate for the saturant.

*Application of the putty.* After the primer became tack-free, a thin layer of putty was applied using a trowel to level the concrete surface and to patch small holes.

*Application of the first layer of saturant.* The first layer of saturant was rolled on the putty using a medium nap roller. The functions of the saturant are: to impregnate the dry fibers, to maintain the fibers in their intended orientation, to distribute stress to the fibers, and to protect the fibers from abrasion and environmental effects.

*Application of the fiber sheet.* After the fiber sheet was measured and pre-cut, it was placed on the concrete surface and gently pressed into the saturant. Prior to removing the backing paper, a trowel was used to remove any air void. After the backing paper was removed, a ribbed roller was rolled in the fiber direction to facilitate impregnation by separating the fibers.

*Application of the second layer of saturant.* A second layer of saturant was applied and worked into the fibers with a ribbed roller. After this, the second fiber sheet could be installed by repeating the described procedure.

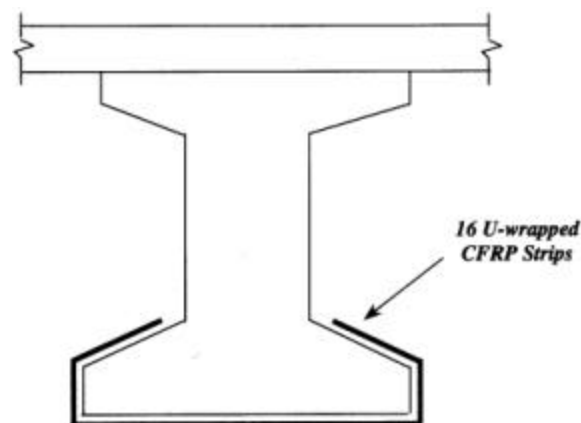

(a) Cross Section

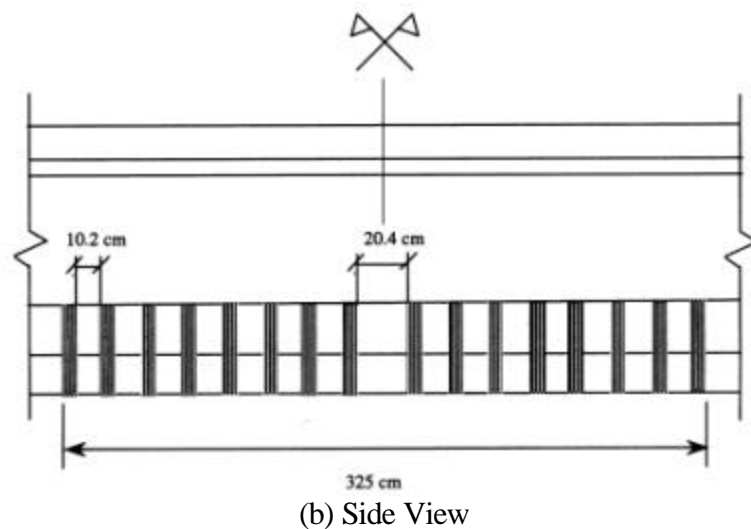

**Figure 4. CFRP Strips U-Wrapped around the Girder Bulb (dimensions in cm)**

Figure 5 shows the Missouri DOT crew at work. The installation of the FRP including surface preparation as described was performed in one morning.

#### CONCLUSIONS

Traditional techniques used to repair concrete structures may be expensive, time consuming, and of limited effectiveness. Due to the inherent physico-mechanical properties of non-metallic composites and their ease of installation, it may be possible to develop new repair methods that are externally adhered to the concrete member. This paper describes a case study where an impact-damaged PC girder was upgraded using FRP laminates installed by manual lay-up. Although, the described strengthening technique offers an efficient option for the repair/retrofit of bridge girders, its successful and widespread implementation will ultimately depend on the engineers' materials and structural knowledge as well as contractors' quality installation. The widespread use of FRP laminates as external reinforcement for concrete also depends on the availability of national or international standards for design, testing, and inspection.

Nanni, A., P.C. Huang and G. Tumialan, "Strengthening of Impact-Damaged Bridge Girder Using FRP Laminates," 9<sup>th</sup> Int. Conf., Structural Faults and Repair, London, UK, July 4-6, 2001, M.C. Forde, Ed., Engineering Technics Press, CD-ROM version, 7pp.



**Figure 5. Installation Crew at Work**

#### ACKNOWLEDGEMENTS

The authors recognize the support from the Missouri Department of Transportation and the University Transportation Center based at the University of Missouri - Rolla.

#### REFERENCES

- Aboutaha, R, R.T. Leon, and A.H. Zureick, (1997), "Rehabilitation of Damaged AASHTO Type II Prestressed Girder Using CFRP," Proc., II Symposium on Practical Solutions for Bridge Strengthening and Rehabilitation, Kansas City, MO, April, pp. 293-301.
- Dolan, C.W., S. Rizkalla and A. Nanni, Editors, (1999), Fiber Reinforced-Polymer Reinforcement for Concrete Structures – Fourth International Symposium (FRPRCS4), ACI Special Publication No. 188, American Concrete Institute, Farmington Hills, MI, 1182 pp.
- Klaiber, F.W., T.J. Wipf, F.M. Russo, R.R. Paradis, and R.E. Mateega, (1999), "Field/Laboratory Testing of Damaged Prestressed Concrete Girder Bridges," Iowa DOT Report HR-397, Iowa State Univ., Ames, Iowa, Dec., 261 pp.
- Master Builders Technologies, (1998), "MBrace Composite Strengthening System - Engineering Design Guidelines," Second Ed., Cleveland, OH, 140 pp.
- Nanni, A., (1997) "Carbon FRP Strengthening: New Technology Becomes Mainstream," Concrete International: Design and Construction, Vol. 19, No. 6, June, pp. 19-23.
- Nanni, A., F. Focacci, and C.A. Cobb, (1998) "Proposed Procedure for the Design of RC Flexural Members Strengthened with FRP Sheets," Proceedings, ICCI-98, Tucson, AZ, Jan. 5-7, Vol. I, pp.187-201.
- Olson, S.A., C. W. French, and R.T. Leon, (1992), "Reusability and Impact Damage Repair of Twenty-Year-Old AASHTO Type III Girders," Research Report No. 93-04, Univ. of Minnesota, Minneapolis, MN, May.
- Prestressed Concrete Institute, (1999), PCI Design Handbook, Fifth Edition, Chicago, Illinois, pp. 4-59~4-63.

Nanni, A., P.C. Huang and G. Tumialan, "Strengthening of Impact-Damaged Bridge Girder Using FRP Laminates," 9<sup>th</sup> Int. Conf., Structural Faults and Repair, London, UK, July 4-6, 2001, M.C. Forde, Ed., Engineering Technics Press, CD-ROM version, 7pp.

Shanafelt, G.O., and W.B. Horn, (1980), "Damage Evaluation and Repair Methods for Prestressed Bridge Members," Transportation Research Board, Washington, DC, NCHRP Report 226.

Shanafelt, G.O., and W.B. Horn, (1985), "Guidelines for Evaluation and Repair of Prestressed Concrete Bridge Members," NCHRP Report 280, Transportation Research Board, Washington, DC.

Zobel, R.S, and J. O. Jirsa, (1998), "Performance of Strand Splice Repair in Prestressed Concrete Bridges," PCI Journal, Vol. 43, No. 6, Nov.-Dec., pp. 72-84.

Zobel, R.S, J.O. Jirsa, D.W. Fowler, and R.L. Carrasquillo, (1997), "Evaluation and Repair of Impact-Damaged Prestressed Concrete Bridge Girders," Report CTR 1370-3F, Univ. of Texas, Austin, TX.